

MATERIAL LIST			
ITEM	REV'D	MATERIAL	DESCRIPTION
1	2	PLYWOOD	3/8" x 13" x 30" LG
2	6	3/4" GRADE "A" PLYWOOD	PLYWOOD 3/8" x 13" x 30" LG
3	2	PLYWOOD	3/8" x 13" x 30" LG
4	14	SPEARHAR PTF 198-1848K	LIFT-OFF HINGE 3WD x 4" LG
5	10	RM375927	3/8" ROLL PINS
6	84	PAN HEAD WOOD SCREWS	*12 PAN HEAD WOOD SCREWS x 1 1/2" LG

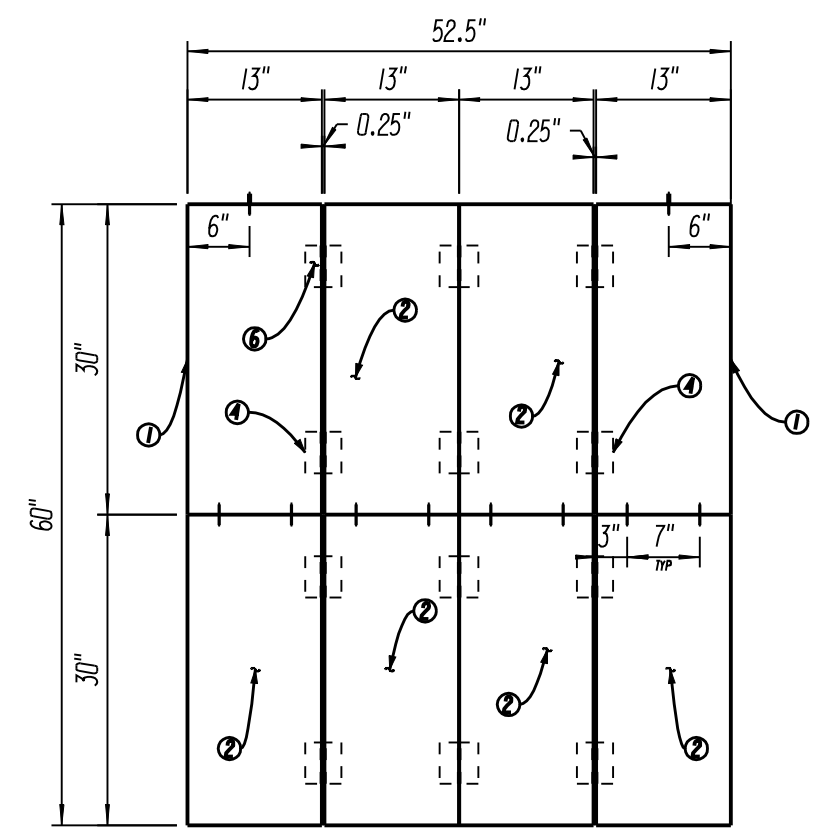

FRONT VIEW ASSEMBLY
BACKBOARD PANEL LAYOUT

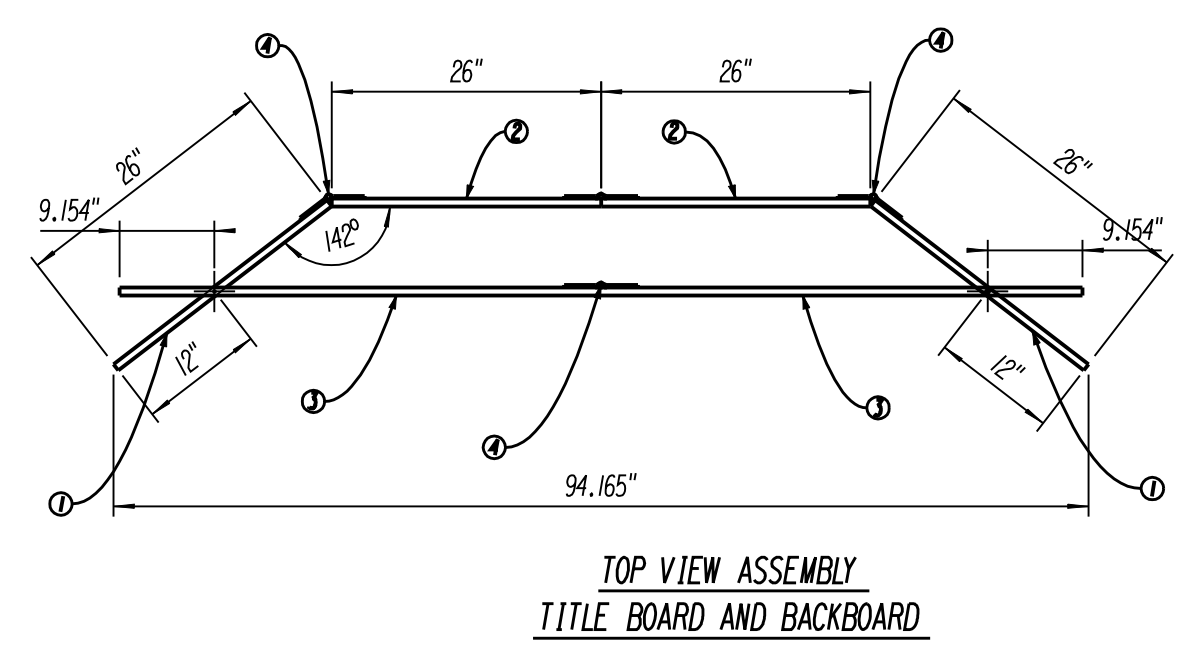
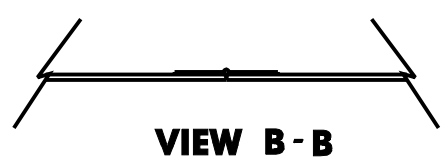
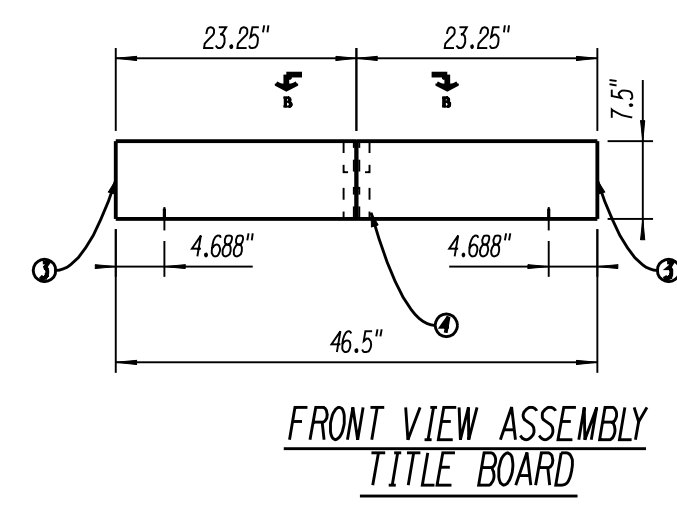
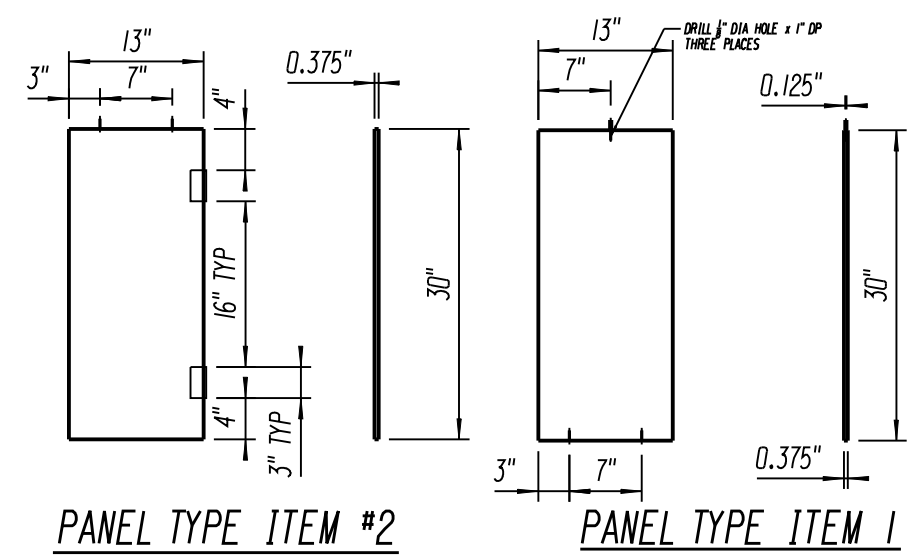
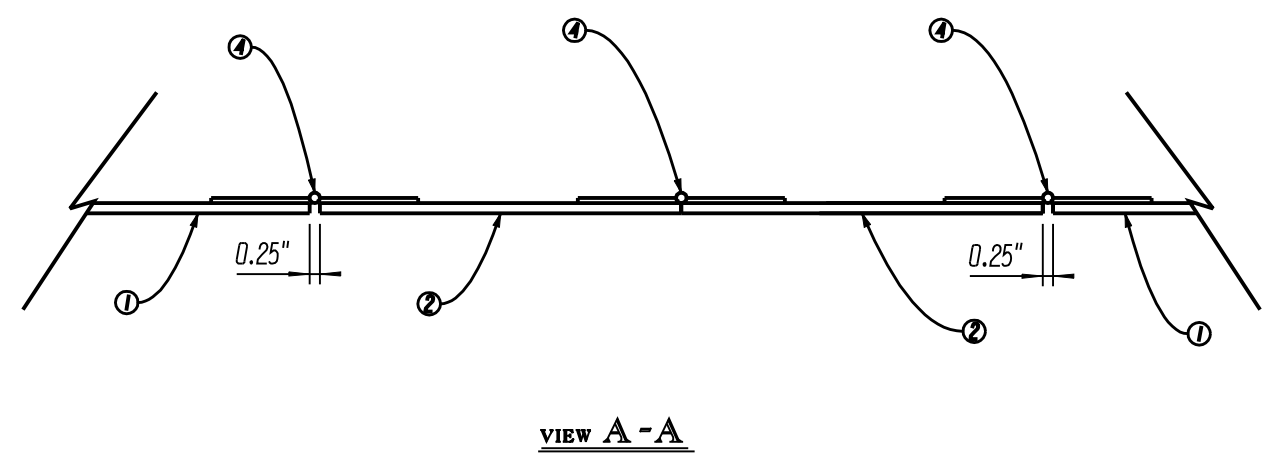

VIEW A-A

TOP VIEW ASSEMBLY
BACKBOARD

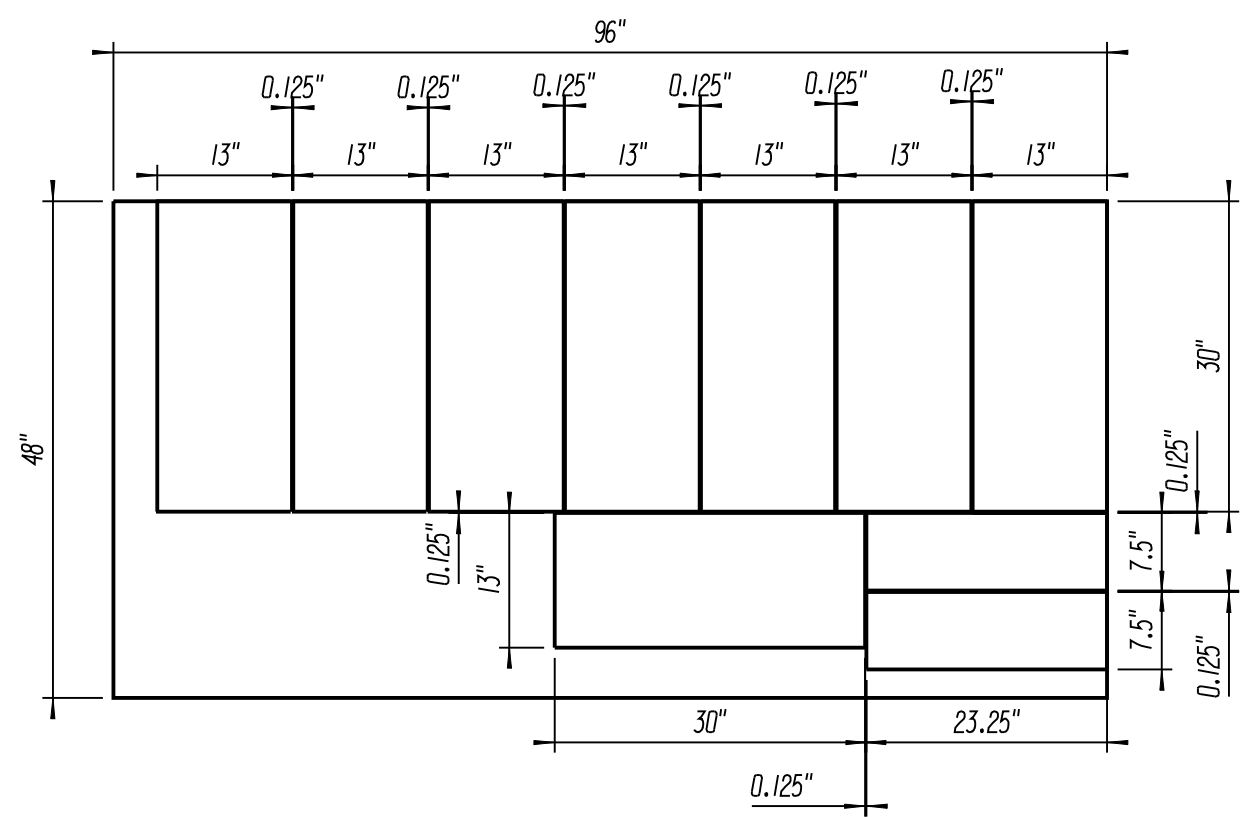

CUT PATTERN

STANDARD MACHINING PRACTICES - PERMISSIBLE VARIATIONS IN INCH DIMENSIONS WITHOUT TOLERANCES UNLESS OTHERWISE SPECIFIED		IMPERIAL DIMENSIONS IN INCHES UNLESS SPECIFIED	THIRD ANGLE PROJECTION
MACHINE SURFACE TOLERANCES	FINISH IN MICROINCHES	INTERPRET DRAWING IN ACCORDANCE WITH CAN3-B78.1 LATEST REVISION DIMENSIONS AND TOLERANCES ARE IN ACCORDANCE WITH CAN/CSA-B78.2	
X.XXX 3-PLACE DECIMAL ±0.005	✓✓✓ INDICATES SURFACE		
X.XX 2-PLACE DECIMAL ±0.010	ANGLE TOLERANCE ±0.5 DEGREE	FABRICATION TOLERANCES:	UNDER 24" ±0.06" OVER 24" ±0.12"
X.X 1-PLACE DECIMAL ±0.020	CHAMFER ALL THREADED FEATURES.		
X 0-PLACE DECIMAL ±0.040	INTERNAL AND EXTERNAL TO THE ROOT OF FIRST THREAD.	FILLIETS SHOWN SHARP 0.02" R, MAX.	
CONCENTRICITY 0.002" T.I.R.	BREAK CORNERS 0.03" X 45° MAX.	TOLERANCES NOT ACCUMULATIVE	

GENERAL	PLANTS GENERAL	PLANTS GENERAL EQUIPMENT	SHOPS AND PLANTWIDE EQUIPMENT	LOCKERS RACKS WORK BENCH TANKS	MISCELLANEOUS	SCIENCE FAIR BACKBOARD	BACK BOARD DETAILS

REV. NO.	DATE	ZONE	REVISIONS
01	NOV 28, 2008		REVISED BY: W. DUMANSKI
ADD CUT PATTERN VIEW			
01	OCT 22, 2008		DRAWN BY: W. DUMANSKI
02	OCT 22, 2008		CHECKED BY: RAY KRANYAK

SCALE: 1"=1'-0"

0011 1190 007 01